

**Seitenkanal-Vakuumpumpen,
mit Frequenzumformer, einstufig**
**Side channel vacuum pumps,
with frequency inverter, single stage**
**Pompes à vide à canal latéral,
avec convertisseur de fréquence, mono étagées**
**Aspiratori a canale laterale
con convertitore di frequenza (inverter), monostadio**

VAU SV 8.130/1- 401

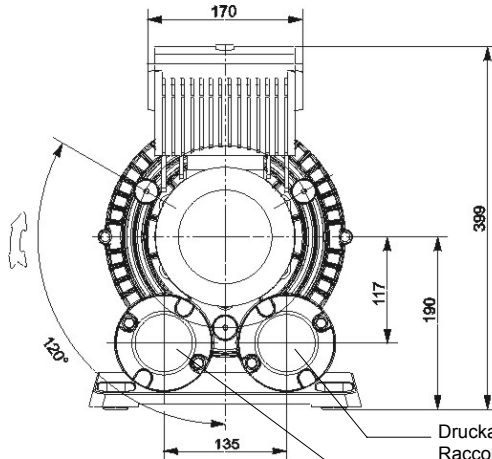

Druckanschluss / Pressure connection /
Raccord pression / Raccordo pressione G 2"
 Sauganschluss / Suction connection /
Raccord aspirazione / Raccordo aspirazione G 2"

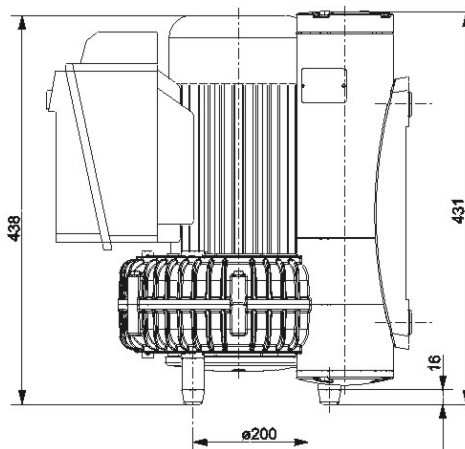
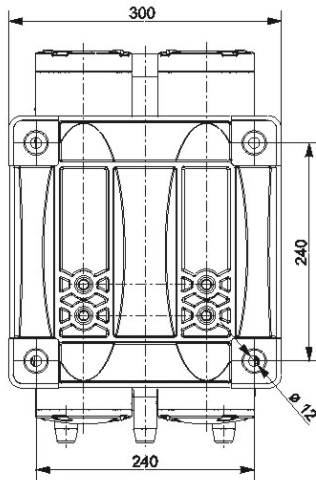

Installierte Motorleistung (Frequenzumformer) Motor capacity installed (frequency inverter) Puissance du moteur installé (convertisseur de fréquences) Potenza del motore installato (convertitore di frequenza)	Spannung Voltage Voltage Voltage	Nennstrom Amp rate Courant Corrente	Frequenz Cycles Fréquence Frequenza	Drehzahl [U/min] Speed [RPM] Vitesse de rotation [T/min] Velocità di rotazione [G/min]
[kW]	[V]	[A]	[Hz]	
4,0 (2,2)	400 ± 10 %	4,85	≤ 100	≤ 5780
4,0 (4,0)	400 ± 10 %	8,50	≤ 100	≤ 5780
Max. Saugluftmenge Max. suction air rate Max. débit d'air aspiré Mas. volume d'aria aspirata	Max. Unterdruck Max. vacuum Max. vide Mas. vuoto	Schallpegel bei Sound level by Niveau sonore à Livello di pressione acustica per -150 mbar / 100 m³/h	Gewicht Weight Poids Peso	
[m³/h]	[mbar]	[dB(A)]	[kg]	
235	-195	74 *	31,5	
235	-250	74 *	31,5	

Maßangaben in mm / Measures in mm / Mesures en mm / Misure in mm

* = bei mittlerer Belastung (Abstand 1 m, beide Seiten abgeleitet) / at medium load (distance 1 m, air discharged on both sides) / à régime moyen (distance 1 m, évacuation d'air des deux) / a medio regime (distanza 1 m, scarico aria su entrambi i lati)

Änderungen vorbehalten / Right of modification reserved / Sous réserve des modifications / Sotto riserva di modificazioni (17.02.03)

Max. Abgastemperatur [°C]
 Max. exhaust air temperature [°C]
 Max. température d'air à l'échappement [°C]
 Mas. temperatura dell'aria scarica [°C]

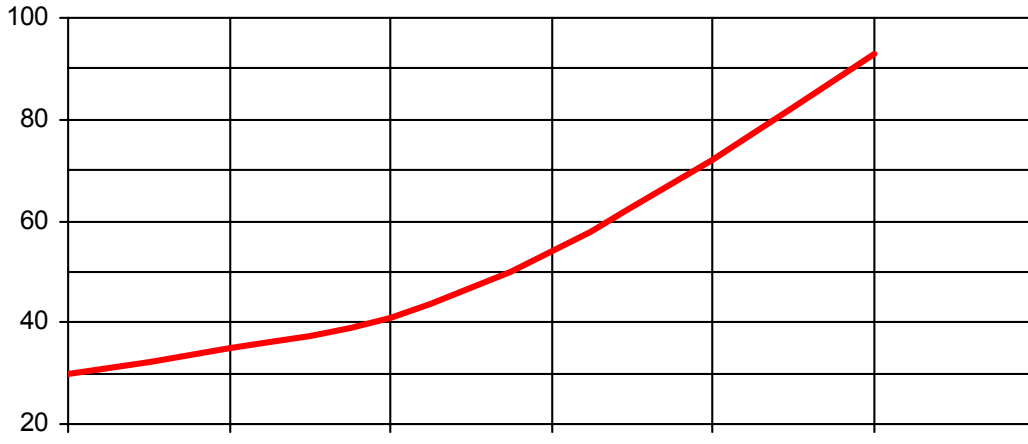

Mögliche Abweichung ±5%
 Allowable tolerance ±5%
 Variation possible ±5%
 Variazione possibile ±5%

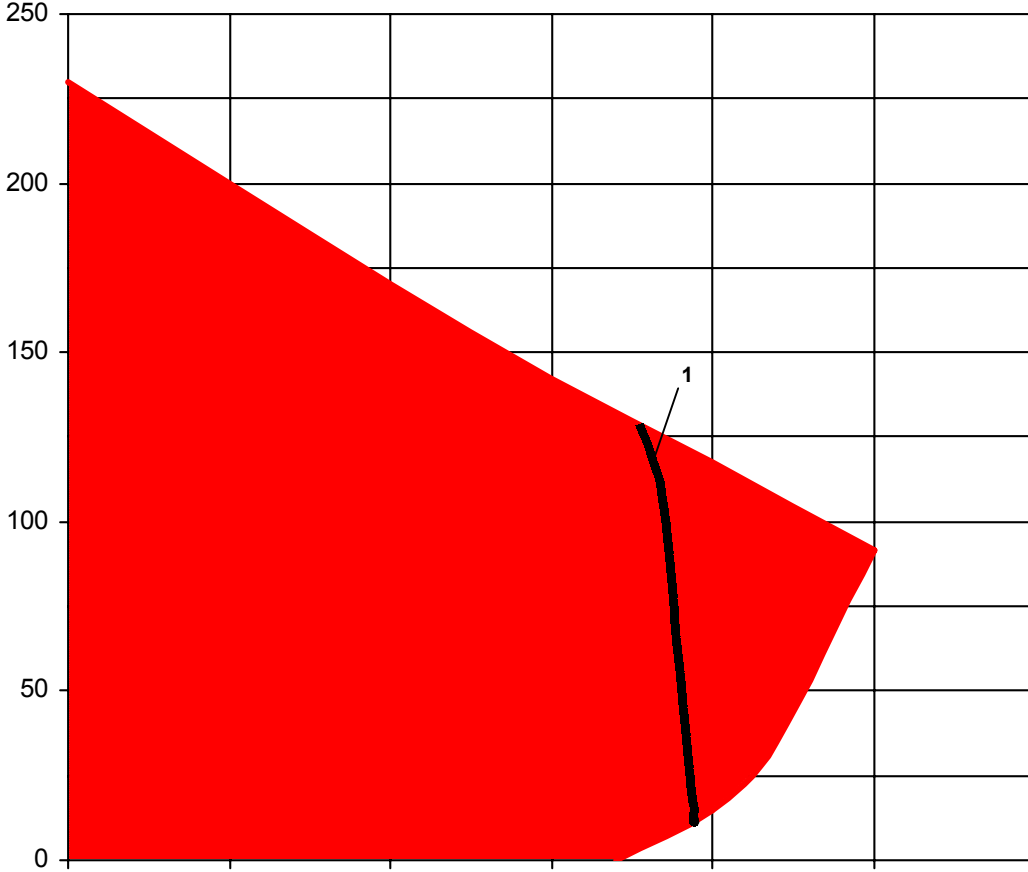

Saugluftmenge [m³/h]
 Suction air rate [m³/h]
 Débit d'air aspiré [m³/h]
 Volume d'aria aspirata [m³/h]

Max. Antriebsleistung [kW]
 Max. motor capacity [kW]
 Max. puissance du moteur [kW]
 Mas. potenza del motore [kW]

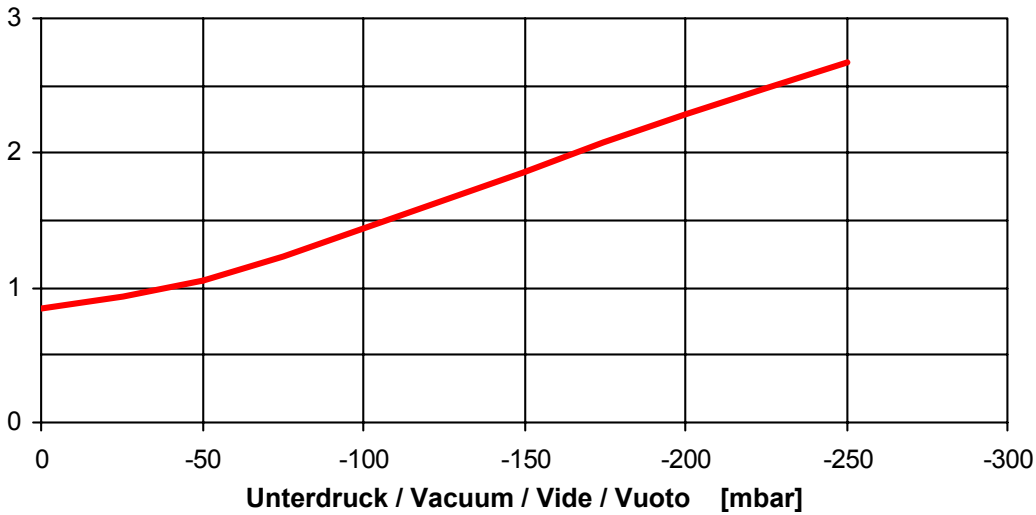

1 = Leistungsgrenze 2,2 kW Frequenzumrichter
 Capacity limit 2.2 kW frequency inverter
 Capacité limit 2.2 kW convertisseur de fréquences
 Capacità limite 2,2 kW convertitore di frequenza

Bezugsdaten: Atmosphäre / Référence: Atmosphere /
 Référence: Atmosphère / Riferimento: Atmosfera 1000 mbar; 20°C
 Änderungen vorbehalten / Right of modification reserved /
 Sous réserve des modifications / Sotto riserva di modificazioni (17.02.03)